

6.1- Unit Specifications

5- 45° Inside corner block

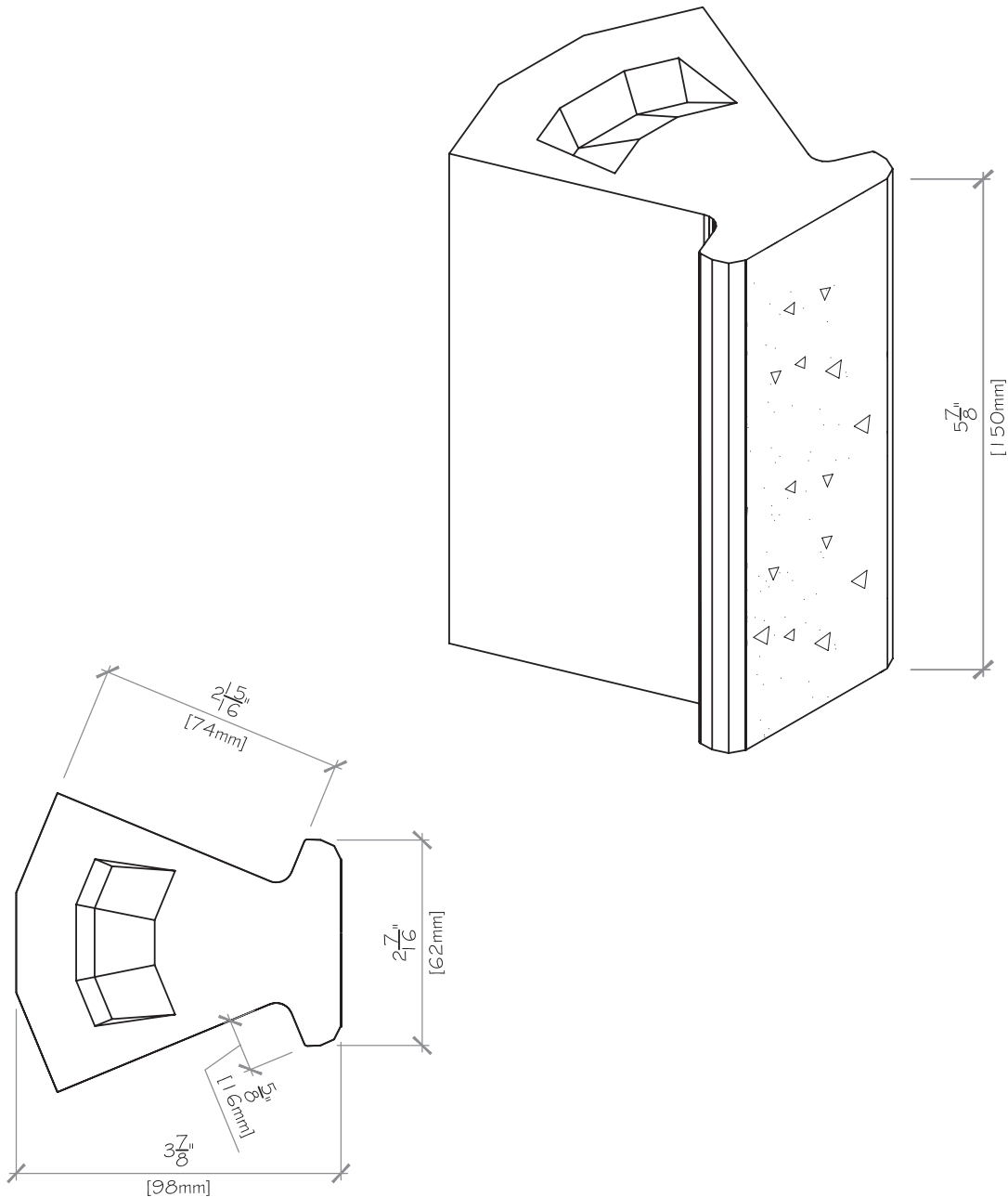

SPECIFICATIONS

Split face length: 2 7/16" (62mm)

Split face height: 5 7/8" (150mm)

Weight: 4.0 lbs / brick or 8.0 lbs / ln.ft.
 1.8 kg / brick or 11.9 kg / ln.m

Coverage: 2 bricks / ln. ft. (6.6 bricks / ln.m)

Material: Concrete

Compressive strength: 3600 psi (25 Mpa)

Maximum water absorbtion: 4 to 5%

