

6.1- Unit Specifications

3- 45° Outside corner block

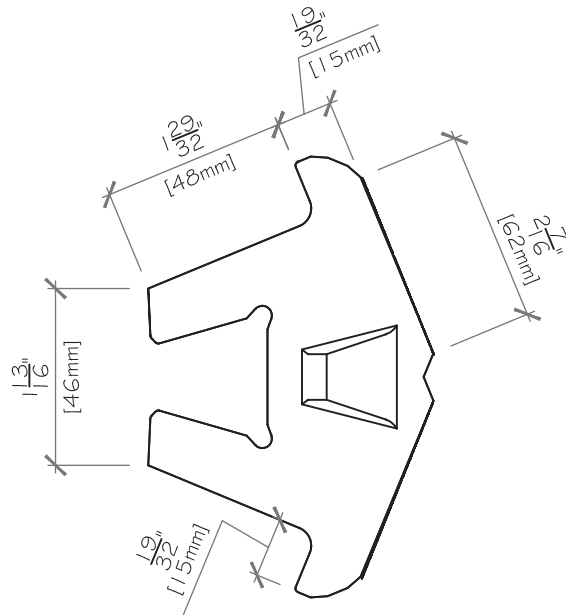
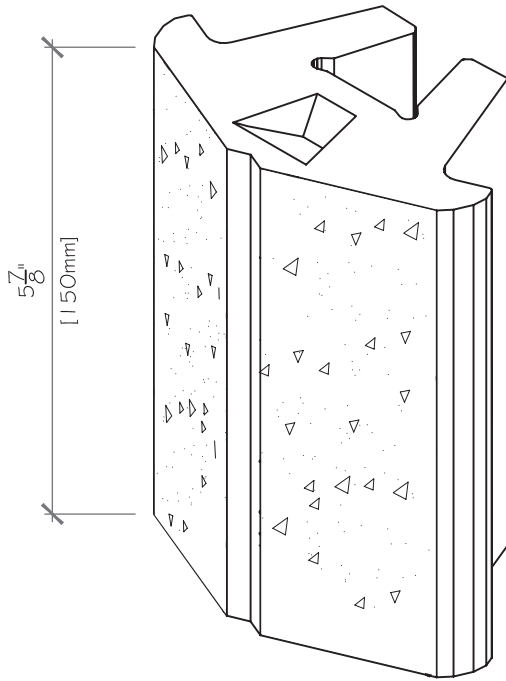
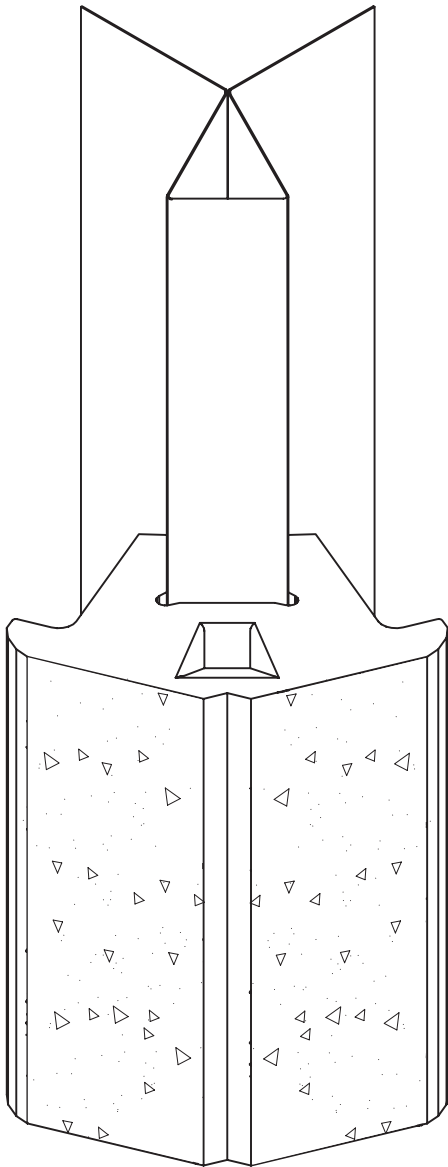

SPECIFICATIONS

Split face length: $2\frac{7}{16}$ " (62mm)

Split face height: $5\frac{7}{8}$ " (150mm)

Weight: 3.1 lbs / brick or 6.2 lbs / ln.ft.
1.4 kg / brick or 9.4 kg / ln.m

Coverage: 2 bricks / ln. ft. (6.7 bricks / ln.m)

Material: Concrete

Compressive strength: 3600 psi (25 Mpa)

Maximum water absorption: 4 to 5%

