

6.1- Unit Specifications

2- 90° Outside corner block

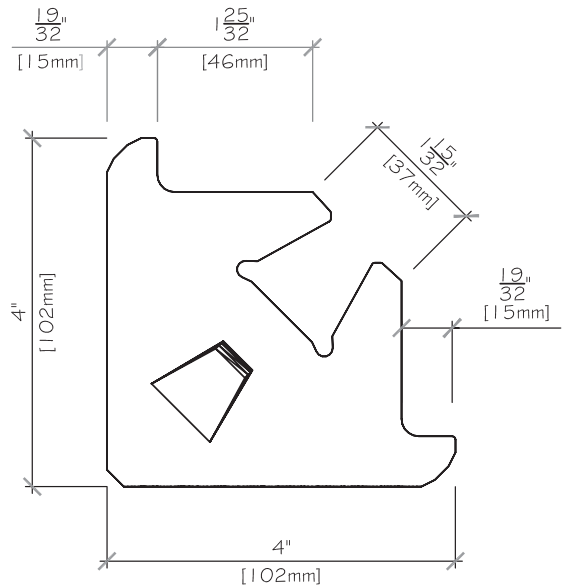
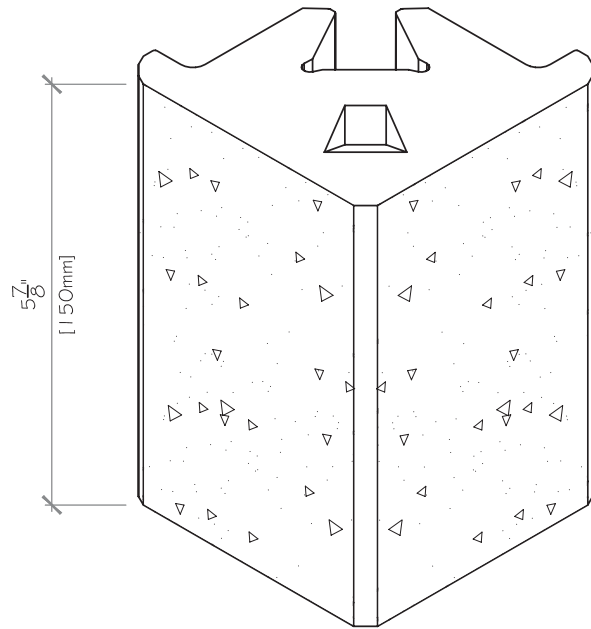
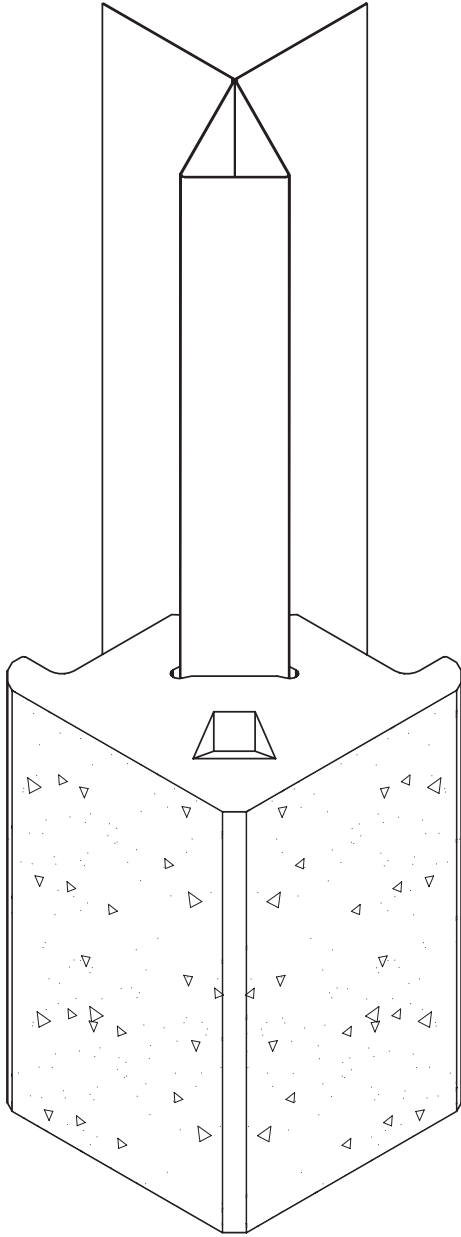

**SPECIFICATIONS**

Split face length: 4" (102mm)

Split face height: 5 7/8" (150mm)

Weight: 5.5 lbs / brick or 11.0 lbs / ln.ft.  
2.5 kg / brick or 13.9 kg / ln.m

Coverage: 2 bricks / ln. ft. (6.6 bricks / ln.m)

Material: Concrete

Compressive strength: 3600 psi (25 Mpa)

Maximum water absorption: 4 to 5%

